

specifications

SKB900-A Series

ActiveCore Series, 2 Door (Glass), Upright Fridge

Project: _____

Item No: _____

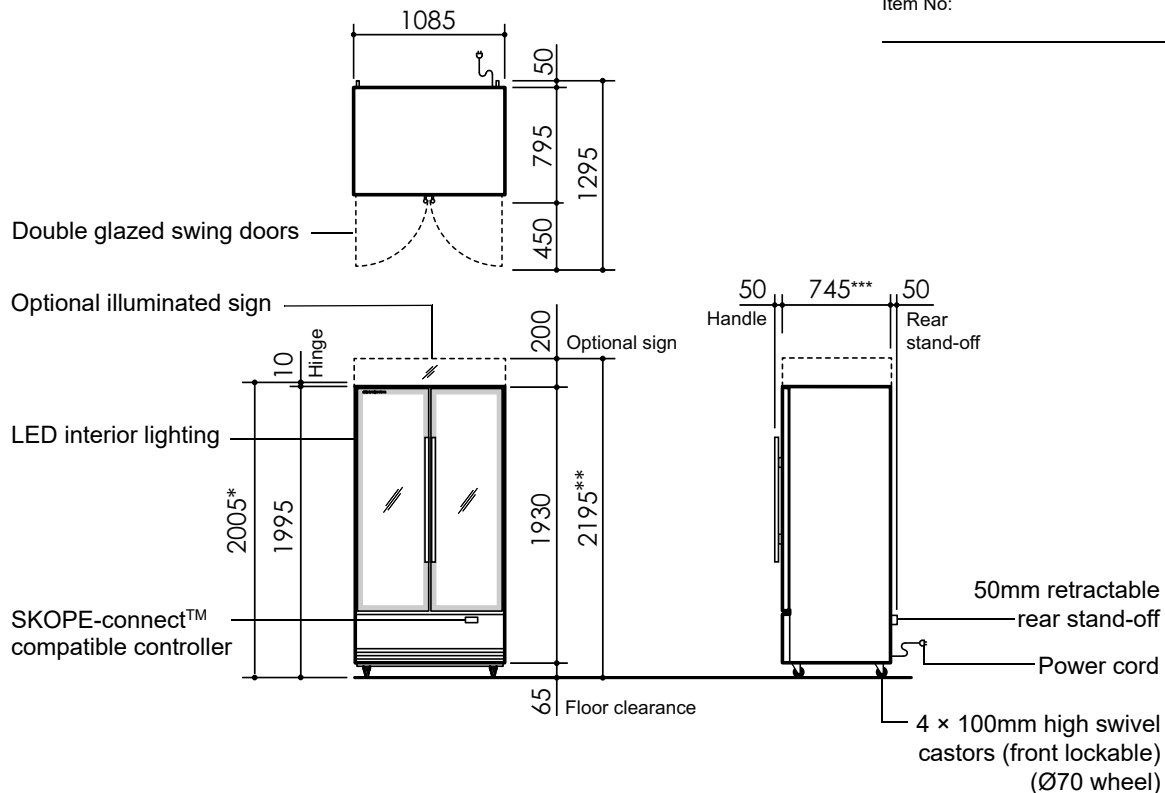

| CABINET | | | |
|---------------------------|--|-----------------------------------|-----------------------------------|
| Model ID | SKB900N-A | SKB900N-AC | SKB900N-ACX |
| SKOPE ID | MB90GYN | MB90BYN | MB90BXN |
| Doors | 2 x self-closing, double glazed, single Low-E, lockable, argon filled, toughened safety glass swing door (hinged LH, RH) | | |
| Internal door opening | 2 x door openings: 1454mm high x TBCmm wide | | |
| Shelves | 8 x wire and 2 x stainless steel | 10 x wire and 2 x stainless steel | 10 x wire and 2 x stainless steel |
| Sign | n.a. | Illuminated sign | Illuminated sign |
| Material | Powdercoat galvanized steel or stainless steel interior & exterior | | |
| PERFORMANCE | | | |
| Max. ambient temp. | 43°C | | |
| Temperature range | 1°C to 4°C (adjustable via SKOPE-connect 1°C to 15°C) | | |
| ELECTRICAL | | | |
| Climate class | 5 (40°C/40% RH) | | |
| Interior side lighting | 2 x 1370mm, 15W LED | 2 x 1370mm, 15W LED | n.a. |
| Interior shelf lighting | n.a. | n.a. | 10 x 415mm, 6W LED |
| Sign lighting | n.a. | 1 x 1035mm, 12W LED | 1 x 1035mm, 12W LED |
| Power cord | Supplied with 2.0m, 10 Amp plug and lead | | |
| Power supply | 220-240 Volts a.c. 50 Hz, single phase supply | | |
| Current draw | 3.0 Amps (includes unit 2.6 Amps) | | |
| REFRIGERATION | | | |
| Controller | SCS Connect (SKOPE-connect™ compatible) | | |
| Connectivity interface | Bluetooth® wireless technology | | |
| Refrigeration system | Bottom mounted, integral, removable ActiveCore refrigeration unit (UBHCNI-0008) | | |
| Refrigerant | R290 / 99g (natural refrigerant) | | |
| Nominal capacity | 740 Watts | | |
| Heat rejection (Avg/peak) | 170 Watts/220 Watts | | |
| Drainage | No plumbing required | | |

| DIMENSIONS | | |
|------------|-----------------------------------|--------------------|
| Height | External 2005mm* / 2195mm** | Internal 1454mm |
| Width | 1085mm | 985mm |
| Depth | 795mm | 602mm |
| Floor area | 0.86m ² | |
| Weight | 220kg | |
| Volume | 880 litres | |

* Height 2005mm without sign (SKB900-A)
** Height 2195mm with sign (SKB900-AC, SKB900-ACX)
*** Depth 745mm excludes removable door handle, door lock bracket and rear stand-off

| Dimensional tolerances | | |
|--|----------------------------|------------------|
| Before installing this cabinet allow the following dimensional tolerances: | | |
| Linear dimensions | Overall cabinet dimensions | |
| Less than 1 metre | ±5mm | |
| More than 1 metre | -5mm to +10mm | |
| Length of multiple cabinets | | |
| | At each joint | At each end wall |
| Less than 1 metre | ±5mm | +15mm |
| More than 1 metre | -5mm to +10mm | +15mm |

| Ventilation requirements | |
|--------------------------|--------------|
| Top | 50mm |
| Sides | Not required |
| Back | 50mm |
| Bottom | 50mm |

SKOPE Industries Limited reserve the right to alter specifications without notice. Copyright © 2018 SKOPE Industries Limited

SKOPE INDUSTRIES LIMITED

Australian Freephone: 1800 121 535, New Zealand Freephone: 0800 947 5673

Email: skope@skope.com, Website: www.skope.com

PSS0572 Rev. 1.1 Oct. 2019

